



# Scanning Microwave Microscope

## Application Note

F. Michael Serry

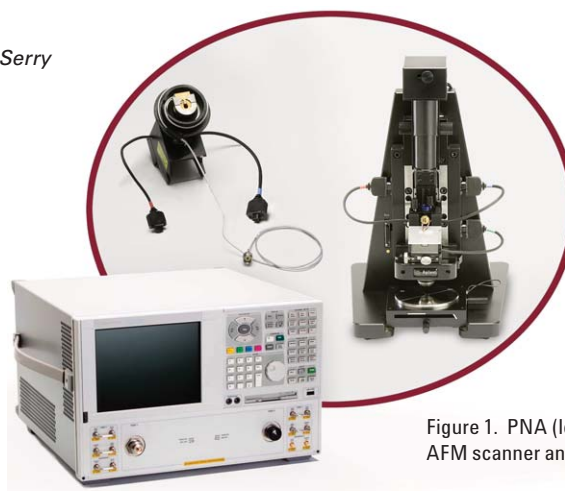

Figure 1. PNA (left) and AFM scanner and 5400 (right).

### Introduction

Measuring electromagnetic properties of materials can provide insight into applications in many areas of science and technology, and increasingly, these properties need to be evaluated at the nanometer scale. Since electromagnetic properties, such as the dielectric constant, are ultimately related to a material's molecular structure, correlating the detailed physical structure of a material with its electromagnetic properties is frequently more valuable than the knowledge of either alone.

Agilent Technologies' Scanning Microwave Microscope (SMM) is a new Scanning Probe Microscope (SPM) that combines the electromagnetic measurement capabilities of a microwave Vector Network Analyzer (VNA) with the nanometer-resolution and Angstrom-scale positioning capabilities of an Atomic Force Microscope (AFM).

Agilent VNAs are mature, highly sophisticated characterization instruments that make extremely accurate, calibrated measurements of complex-valued ratios on electromagnetic signals. The ratios are  $R = \frac{\text{reflected signal}}{\text{incident signal}}$ , and  $T = \frac{\text{transmitted signal}}{\text{incident signal}}$ .

The incident signal is generated and controlled inside the VNA; as a result, the

ratios  $R$  and  $T$  are not merely relative, but referenced to the well-known, accurately quantified *incident signal*.

This measurement capability, delivered to the apex of an AFM tip makes the SMM the only SPM in its class, enabling calibrated, traceable measurements of electrical properties such as impedance and capacitance, with the high spatial resolution that is the hallmark of a well-designed, well-constructed AFM.

### Microwave Vector Network Analyzer

The SMM uses Agilent's PNA N5230A microwave vector network analyzer (Figure 1).<sup>1</sup> Like all network analyzers, this VNA is a stimulus-response instrument, optimized for accurate and repeatable measurement of the response of a network or a device under test (DUT) to a *known stimulus* signal. This is in contradistinction to instruments such as the spectrum analyzer, which are usually configured as a receiver (only) of an unknown signal, and which do not include a source for a stimulus to be applied to the DUT.

A VNA has two operational modes: transmission and reflection. In the reflection (alternatively, transmission) mode, the VNA measures the magnitude and phase characteristics of the DUT

<sup>1</sup> The main difference between a scalar network analyzer and a VNA is the ability of the VNA to make phase measurements.

by comparing the signal that reflects off (alternatively, transmits through) the device with the stimulus signal.<sup>2</sup> Each mode enables measurement of several useful parameters. In the reflection mode, the VNA can measure (among other things) the impedance of the DUT.<sup>3</sup> Scanning Impedance Microscopy is a major application of the SMM.

### Scanning Impedance Microscopy

One of the most common applications of network analysis is measuring the impedance of a component, so as to evaluate if it matches the impedance of the other components with which it must interface in a network. Impedance measurement techniques in network analyzers have become quite advanced and refined.

The SMM uses the VNA in reflection mode for measuring the impedance of the “network” that includes the tip-sample interface.<sup>4</sup> In the SMM, the DUT for the VNA consists of the AFM probe and the region of the sample immediately beneath the metal-coated AFM tip. One application of impedance measurement with SMM is scanning capacitance microscopy (SCM) of semiconductors. Here the AFM tip and the semiconductor sample form a metal-oxide-semiconductor (MOS) capacitor. (More on SCM later).

The incident microwave travels through a series of components before it reaches the tip-sample interface by means of a transmission line. The impedance mismatch between the transmission line and the DUT causes the incident microwave to partially reflect from the tip-sample interface back towards the stimulus signal source inside the VNA; this reflected signal is proportional to the impedance mismatch. The incident microwave and the reflected microwave together contain information about the impedance of the DUT. See “Sidebar” for more detail.

### Scanning Capacitance Microscopy

Measuring the capacitance-to-ground (C) of the tip-sample interface, and its variation (dC/dV) with an applied AC bias ( $V=V_0 \sin[\omega t]$ ) is an important extension of atomic force microscopy (AFM) for the electrical characterization of semiconductors. It enables a two-dimensional mapping of the carrier density across different regions of a semiconductor, with applications in the failure analysis, characterization, modeling

### VNA Reflection Mode Measurement of Impedance

Impedance may be measured in three different ways, according to the frequency and the magnitudes involved. A VNA measures a DUT’s impedance by comparing the reflected signal to the incident signal (the reflection method). This method of measuring impedance is the one that works best at the microwave frequencies and for impedance values at or near the characteristic impedance of transmission lines (50 Ω or 75 Ω). The accuracy of a VNA impedance measurement reduces however as the impedance values move away from these characteristic values.

At the heart of SMM’s VNA-based impedance measurement technique is a simple yet effective scheme that brings the instrument’s reflection-mode measurement capabilities to bear upon solving the problem of measuring with a very high resolution the small changes of a very small impedance (capacitance): that of the (AFM tip/semiconductor) MOS capacitor to the RF ground.

Figure 2 shows how  $r$ , the magnitude of the complex-valued reflection coefficient  $S_{11}$ , changes with both the load impedance  $Z_L$  and the source impedance  $Z_S$  (internal to the VNA).<sup>5</sup>

$$S_{11} = \frac{Z_L - Z_S}{Z_L + Z_S}$$

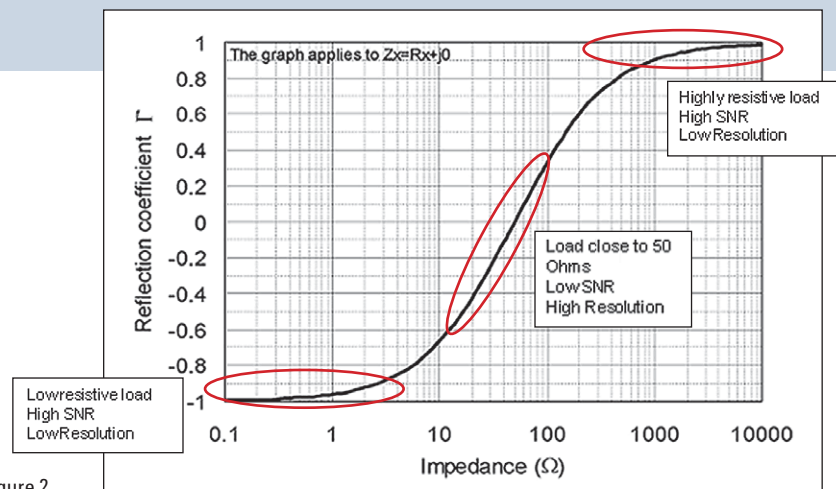

Figure 2.

<sup>2</sup> In some older model network analyzers, the stimulus signal was taken from a separate source. In Agilent’s PNA N5230A, the knowledge of the stimulus signal is excellent, because it is a (microwave) signal generated inside the VNA with high resolution and stability of both the amplitude and the frequency.

<sup>3</sup> Impedance is the total resistance that a DUT presents to the flow of an ac signal at a given frequency.

<sup>4</sup> The word network as used in “network analyzer” is generic and broadly defined. The origin of its usage (as it now relates to network analysis) goes back to the seminal work of the founders of The Hewlett Packard Company, formerly the parent company of Agilent Technologies. Bill Hewlett and David Packard used the term network to refer to the electronic circuits they were using to test their first products, which started with signal generators! But as it is used today, the word network can for example apply to a liquid sample or a plastic sample or even a food sample as a DUT in network analysis.

<sup>5</sup>  $S_{11}$  is one of four scattering parameters (*S-Parameters*), which are used to characterize the response of a DUT at high frequencies, in a way that is consistent with transmission line theory. All four *S Parameters* are ratios of voltage traveling waves entering and exiting the DUT. For more information, please visit Agilent’s website: <http://wireless.agilent.com/networkanalyzers/pnademo.htm>

When the value of  $Z_L$  is close to that of  $Z_S$ , the plot has the steepest slope, which corresponds to the highest sensitivity and the highest resolution.  $Z_S$  is 50  $\Omega$ , but  $Z_L$  is generally not near this value.

In order to bring the value of  $Z_L$  closer to that of  $Z_S$  and therefore exploit the VNA's impedance measurement capability in its most accurate and sensitive range, the SMM uses a half-wavelength impedance transformer to place the measurand—the DUT—directly across an external 50  $\Omega$  impedance, that is, parallel to it (Figure 3). In this way, the SMM operates the VNA with the sensitivity and resolution required to measure capacitance changes on the order of 0.1aF across a 0.1fF base capacitance. Furthermore, this impedance transformation is done at a location that is physically remote from the tip-sample interface, thereby facilitating mechanical design implementation.

The results of Agilent's ADS Microwave Simulator for this setup (Figure 4) show that the VNA now operates with a resonant structure as its load, thus enabling it to measure minute changes in the value of the capacitance-to-ground for a MOS capacitor that consists of the metallized AFM tip, a semiconductor sample, and the oxide between them.

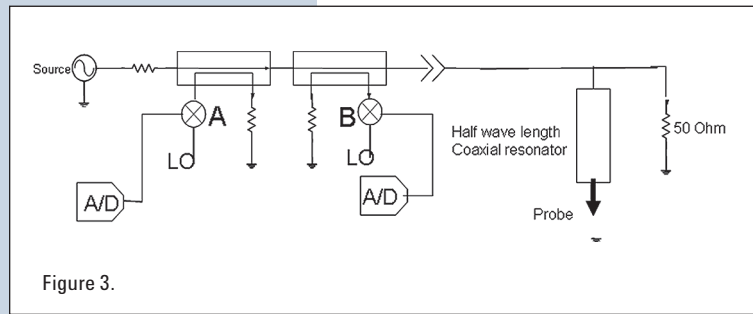

Figure 3.

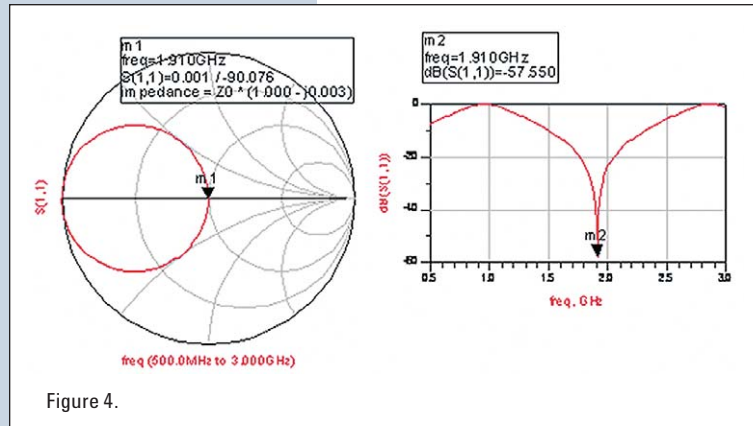

Figure 4.

and simulation of device performance, and also in the development of the semiconductor fabrication process.

Traditionally, a resonant capacitive sensor-based scanning capacitance microscopy (SCM) technique has been used to implement this type of AFM technique with some success. One of the main shortcomings of traditional SCM is the difficulty of making absolute measurements of the strength of the tip-sample electrical interaction; therefore, SCM images remain maps of the *relative* difference in carrier densities across the scanned area. For this reason, accomplishing the much coveted task of using SCM to reliably and repeatedly extract numerical estimates for carrier densities in semiconductor devices remains elusive.

Agilent VNA hardware includes precision components for the calibration and performance verification of the instrument,

thereby extending its applications to those that require calibrated, traceable, and absolute measurements of, for example, capacitance.

The SMM makes high-resolution, calibrated measurements of the capacitance-to-ground between an AFM tip and a semiconductor sample. This ushers the way for the reliable, repeatable extraction of numerical values of the carrier densities in a semiconductor. The SMM typically operates at microwave frequencies of 1.5-6 GHz, which is substantially higher than the frequencies used in traditional SCM (around 900 MHz.) The higher frequencies in SMM lead to better sensitivity and (electrical) resolution for measuring the tip-sample capacitance. The SMM uses a lock-in amplifier for measuring the in-quadrature and in-phase components of  $dC/dV$ , allowing for the determination of the polarity of the majority carriers in the semiconductor.

### Spectroscopy with SMM

SMM brings the vast measurement capabilities of the PNA N5320A to expand AFM-based spectroscopy techniques for electromagnetic characterization, beyond anything that has been available in a commercial product so far.<sup>6</sup> For example, power sweep and frequency sweep capabilities of the PNA N5320A are perfectly suited for characterizing the frequency response of a given location on a sample.

Even the PNA N5320A's most common methods for representing measurements, such as the Smith Chart, and the Linear Phase plot, open up a wide range of possibilities for spectroscopic techniques with AFM. In addition, the PNA N5320A supports and operates (directly on the instrument) numerous material characterization software packages from Agilent; these allow, for example, the measurement of the complex permittivity of a material.

<sup>6</sup> Spectroscopic techniques in AFM are conducted by disabling the AFM's raster scanning, and interrogating the sample at the location of the AFM tip while sweeping a parameter across a range of its values; for example, the amplitude or the frequency of a signal applied to the tip or to the sample. For more information, please visit: <http://cp.literature.agilent.com/litweb/pdf/5989-8215EN.pdf>

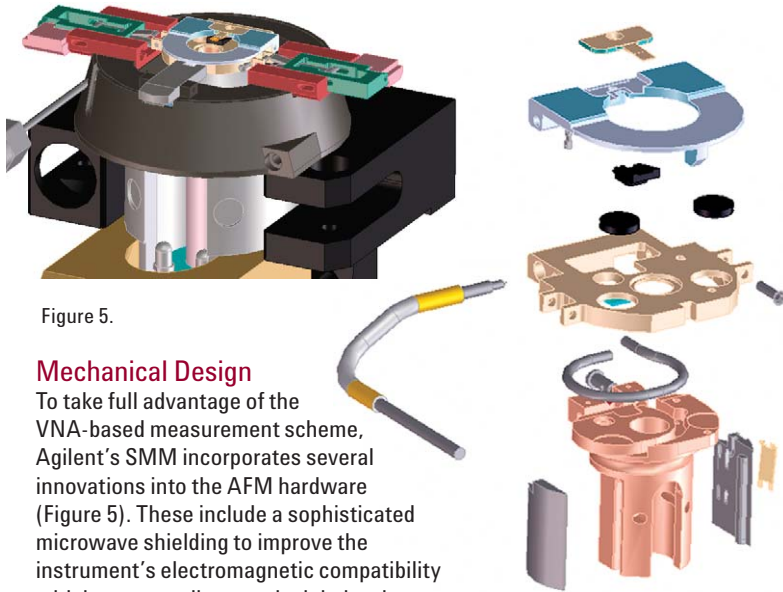

Figure 5.

### Mechanical Design

To take full advantage of the VNA-based measurement scheme, Agilent's SMM incorporates several innovations into the AFM hardware (Figure 5). These include a sophisticated microwave shielding to improve the instrument's electromagnetic compatibility with its surroundings, and minimize the effect of stray capacitances, which are inevitable with the probe's movement during the raster scanning. The innovation of this design is implemented in such a way as to minimize the impact on the performance of the AFM scanner, where the cantilever holder attaches to the rest of the AFM.

### Summary

The Scanning Microwave Microscope (SMM) is a new scanning probe microscope that combines the power of Agilent AFMs with Agilent's 40-year legacy of excellence to deliver new standards in speed, accuracy, and versatility for microwave network analysis. The applications of SMM include highly-localized measurements of impedance, capacitance, and dielectric properties.

The SMM includes robust electromagnetic environment compatibility elements, as well as built-in precision electronic components. These features allow for calibrated and more sensitive measurements than previously possible with other AFM-based techniques for electrical characterization. The SMM paves the way for extracting from the impedance (capacitance) data reliable numerical estimates of the carrier densities in semiconductors.



### Calibrated Measurements

Agilent's PNA N5230A measurements are calibrated with Agilent's "ECal," the electronic calibration kits for fast, simple, accurate calibration of the instrument, including for phase measurements. The instrument's firmware makes the calibration a routine push-button task that completes within seconds.

## AFM Instrumentation from Agilent Technologies

Agilent Technologies offers high-precision, modular AFM solutions for research, industry, and education. Exceptional worldwide support is provided by experienced application scientists and technical service personnel. Agilent's leading-edge R&D laboratories are dedicated to the timely introduction and optimization of innovative and easy-to-use AFM technologies.

[www.agilent.com/find/afm](http://www.agilent.com/find/afm)

[www.agilent.com](http://www.agilent.com)

For more information on Agilent Technologies' products, applications or services, please contact your local Agilent office. The complete list is available at:

[www.agilent.com/find/contactus](http://www.agilent.com/find/contactus)

### Phone or Fax

**United States:** (tel) 800 829 4444  
(fax) 800 829 4433

**Canada:** (tel) 877 894 4414  
(fax) 800 746 4866

**China:** (tel) 800 810 0189  
(fax) 800 820 2816

**Europe:** (tel) 31 20 547 2111

**Japan:** (tel) (81) 426 56 7832  
(fax) (81) 426 56 7840

**Korea:** (tel) (080) 769 0800  
(fax) (080) 769 0900

**Latin America:** (tel) (305) 269 7500

**Taiwan:** (tel) 0800 047 866  
(fax) 0800 286 331

### Other Asia Pacific Countries:

tm\_ap@agilent.com  
(tel) (65) 6375 8100  
(fax) (65) 6755 0042

Product specifications and descriptions in this document subject to change without notice.

© Agilent Technologies, Inc. 2008  
Printed in USA, June 16, 2008  
5989-8818EN